

# 4V400 Series

## Solenoid Valve, Air Piloted Valve



The way to automation

- Valve
- 4V100
- 4V200
- 4V300
- 4V400**
- Manifold
- 3V1
- JEL
- JZF
- MVSD
- VF, VZ
- BM, PU, AM
- Diaphragm
- Coil
- 2V
- 2W
- 2W(Big)
- 2P
- 2L
- VX
- PU
- PU225
- 2Q
- JEL5404
- JEL6213
- Pulse
- JELJZF
- 4H
- TSV
- MPV
- 4HV
- HV, K
- 4R
- 4F
- MSV
- JM
- ASC, RE
- QE, QEA
- ST
- HSV

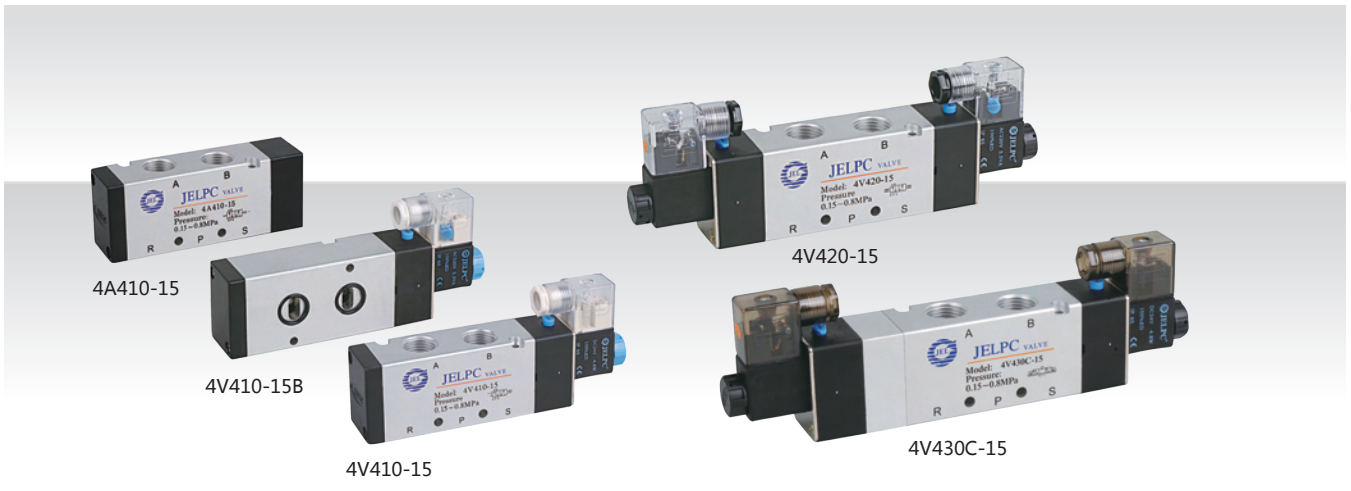

### Ordering Code

4V	4	10	15	B	AC220V	W	F
Specification	Series Code	Coil and Type	Port size	Connection and Initial status	Standard Voltage	Wiring	Joint
4V: 5/2(3) way solenoid valve 4A: 5/2(3) way air pilot valve 3V: 3/2 way solenoid valve 3A: 3/2 way air pilot valve	400 Series	10: Single coil 20: Double coil 30C: Mid-position closed 30E: Mid-position vented 30P: Mid-position open	15: 1/2"	Blank: Threaded B: Sub-plated mounted (for 5/2; 5/3 way only) NC: 3/2 Way normally closed NO: 3/2 Way normally open	DC12V DC24V AC24V 50Hz/60Hz AC110V 50Hz/60Hz AC220V 50Hz/60Hz AC380V 50Hz/60Hz	Blank: Without light indicator LD: Brown with light indicator LD1: White with light indicator W: Lead wire	1 F-20 F

### Specification

Model	4V410-15	4V420-15	4V430C-15	4V430E-15	4V430P-15
Valve Type	5/2 Way			5/3 Way	
Effective Cross Section Area	50 mm <sup>2</sup> (CV=2.79)			30 mm <sup>2</sup> (CV=1.68)	
Model	3V410-15	3V420-15	3A410-15	3A420-15	
Valve Type	3/2 Way				
Effective Cross Section Area	50mm <sup>2</sup> (CV=2.79)				
Port Size	Inlet, Outlet, Exhaust Port = G1/2"				
Working Medium	40 Micron Filtered Air				
Operation	Internal piloted				
Working-pressure	0.15 ~ 0.8 MPa				
Max. Test Pressure	1.2 MPa				
Ambient Temperature	5 ~ 50 °C				
Operating Voltage Tolerance	± 10%				
Power Consumption	AC: 5.5 VA DC: 4.8 W				
Connector Protection	F Class, IP 65				
Wiring / Connector	Cable / Lead Wire or DIN Connector				
Switching Frequency	5 Cycles / Sec.				
Response Time	0.05 Sec.				

### Overall Dimension

4V410-15

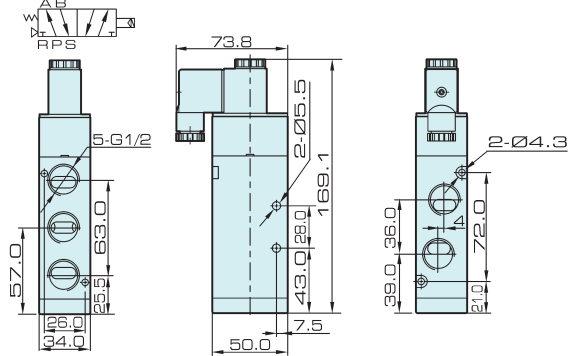

4V420-15

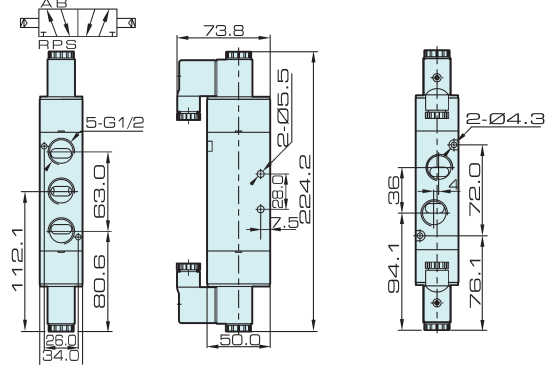

4V430-15

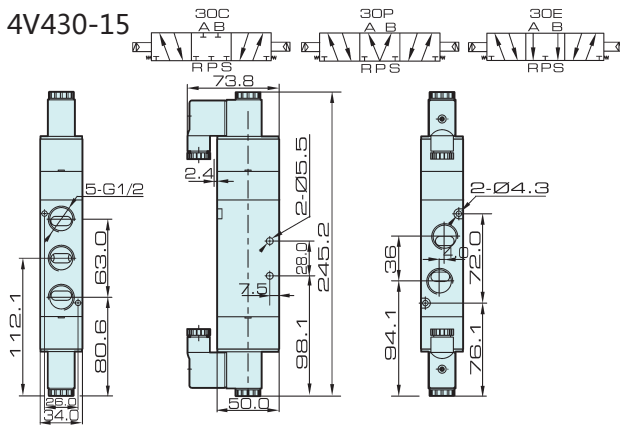

4A410-15

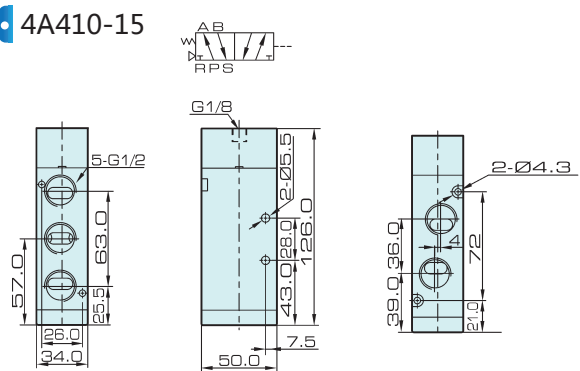

4A420-15

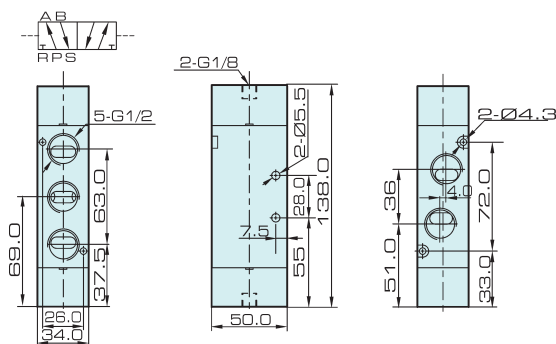

4A430-15

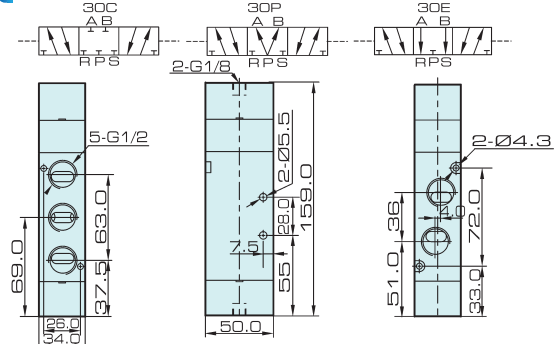

3V410-15

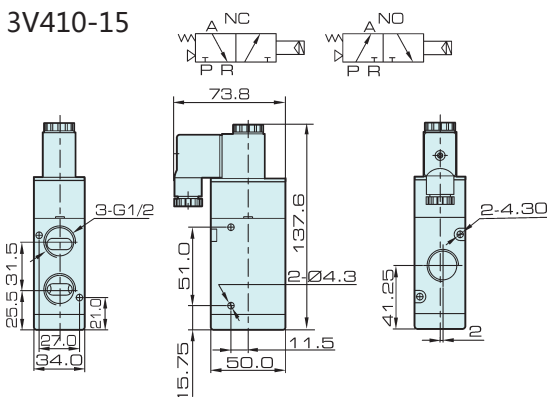

3V420-15

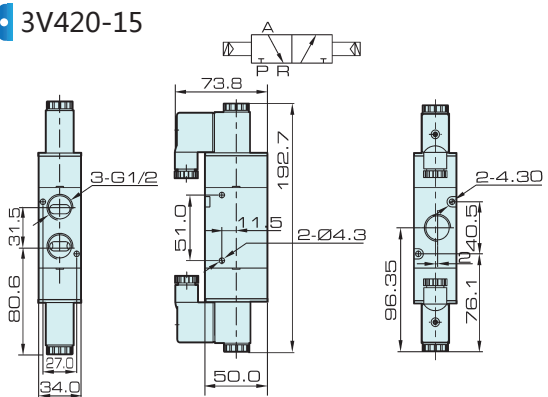

Valve

- 4V100
- 4V200
- 4V300
- 4V400

Manifold

- 3V1
- JEL
- JZF
- MVSD
- VF, VZ
- BM, PU, AM
- Diaphragm

Coil

- 2V
- 2W
- 2W(Big)
- 2P
- 2L
- VX
- PU
- PU225
- 2Q

JEL5404

JEL6213

Pulse

JEL, JZF

4H

TSV86

MPV

4HV

HV, K

4R

4F

MSV

JM

ASC, RE

QE, QEA

ST

HSV

# 4V400 Series

## Solenoid Valve, Air Piloted Valve



The way to automation

### Overall Dimension

- Valve
- 4V100
- 4V200
- 4V300
- 4V400
- Manifold
- 3V1
- JEL
- JZF
- MVSD
- VF, VZ
- BM, PU, AM
- Diaphragm
- Coil
- 2V
- 2W
- 2W(Big)
- 2P
- 2L
- VX
- PU
- PU225
- 2Q
- JEL5404
- JEL6213
- Pulse
- JELJZF
- 4H
- TSV
- MPV
- 4HV
- HV, K
- 4R
- 4F
- MSV
- JM
- ASC, RE
- QE, QEA
- ST
- HSV

#### 3A410-15

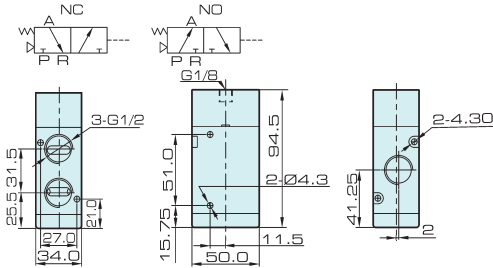

#### 3A420-15

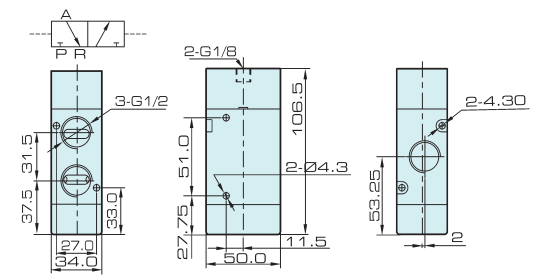

#### 4V410-15B

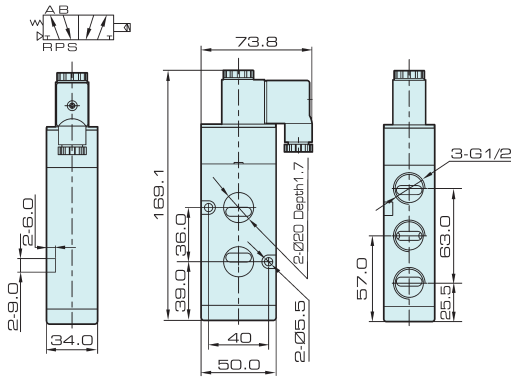

#### 4V420-15B

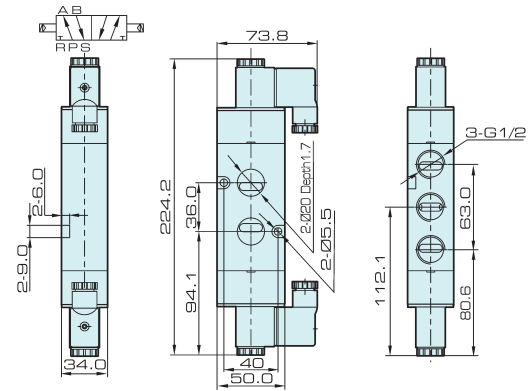

#### 4V430-15B

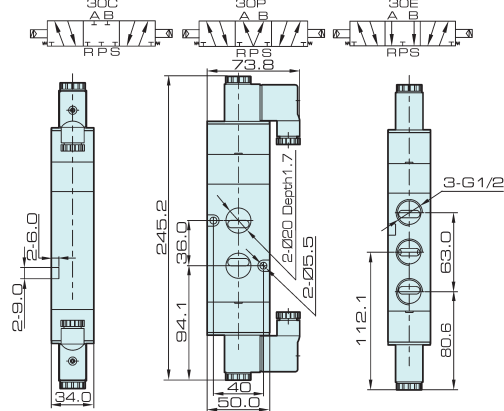

#### 4A410-15B

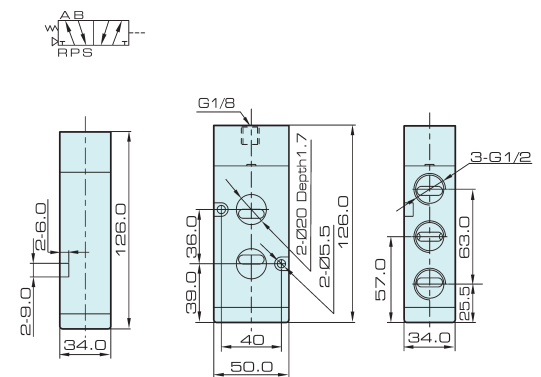

#### 4A420-15B

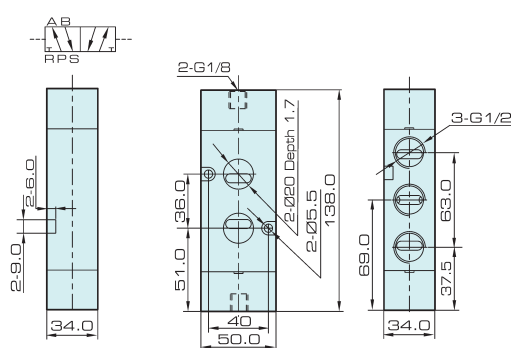

#### 4A430-15B

