



SLE manifold type series solenoid valve

Solenoid Valves Numbering System for Order

Position description	1	2	3	4	5	6	7	8	9	10	
	Valve Series	Mode of Operation	Coil Type	Coil Class	Voltage	Seal Material	Body Material	Pipe Size	Orifice (φ mm)	Manifold	
E.G.	SLE	1	D	F	02	N	1	A	03	N4	<input type="checkbox"/>
Manifold type Solenoid Valve	1: Normally Closed	D: DIN Standard Connections, Fully Encapsulated S: NASS Coil (DIN)	F: F Class	02=220VAC 230VAC 50/60HZ 01=110VAC 120VAC 50/60HZ 05=24VAC 13=DC24V Contact the Factory for Others	N: NBR V: VITON E: EPDM	1= Brass 8= Aluminium (Standard)	A=1/8" B=1/4" C=3/8" D=1/2"	02=2.0 03=3.0 04=4.0 05=5.0 06=6.0 09=9.0	N2=2 N3=3 N4=4 N5=5	L: Neon Lamp N: NPT Connection	

Sanlixin Solenoid Valve

SLE manifold type series solenoid valve

1: 2-Way normally closed solenoid valve; closed when de-energized, open when energized.

2: Body material: brass, aluminum (standard)

3: Ambient Temp. 0°C~65°C; flow as the arrow, one inlet many outlets(N)

4: Coil can fix Germany NASS Coil,

Standard voltage: 220VAC/230VAC/240VAC

50/60HZ 22VA 24VA 24VDC 13W

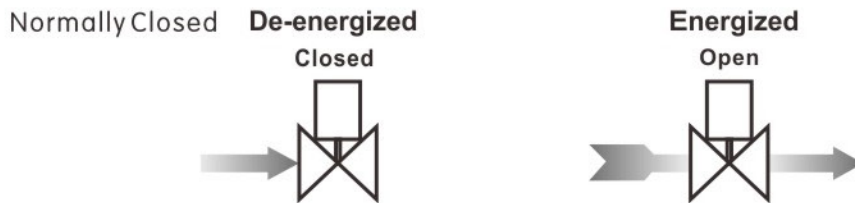

Construction, External Dimensions Chart

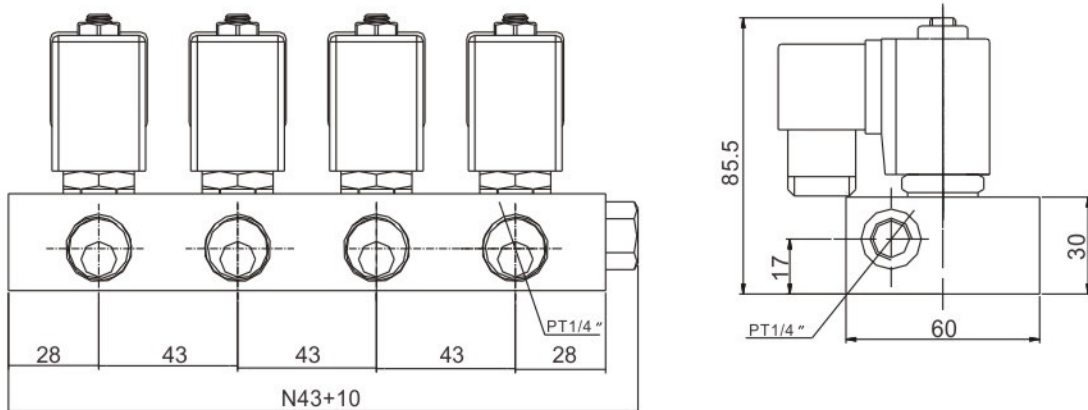



SLE manifold type series solenoid valve

Valve Selection List

Pipe Conn-ection	Orifice mm	Cv Factor	Operating pressure differential (kgf/cm ²)							Max. Fluids Temp.	Coil Type	Power consumption		Coil Class	Model Code Follows Voltage are 220VAC 50/60HZ
			Min.	Max.								VA AC 220 V	W DC 24 V		
				Air Gas		Water Hot water Liquids		Light oil ≤20CST							
				AC 220V	DC 24V	AC 220V	DC 24V	AC 220V	DC 24V						
1/8"	2.0	0.15	0	20	20	20	15	15	10	120	D	22	13	F	SLE1DF02V8A02
	3.0	0.23	0	10	10	10	10	7	7	120	D	22	13	F	SLE1DF02V8A03
	4.0	0.44	0	7	7	7	5	5	5	120	D	22	13	F	SLE1DF02V8A04
	5.0	0.5	0	4	2.5	4	2.5	2.5	2.5	120	D	22	13	F	SLE1DF02V8A05
1/4"	2.0	0.15	0	20	20	20	15	15	10	120	D	22	13	F	SLE1DF02V8B02
	3.0	0.23	0	13	13	13	10	7	5	120	D	22	13	F	SLE1DF02V8B03
	4.0	0.44	0	7	7	7	5	5	5	120	D	22	13	F	SLE1DF02V8B04
	5.0	0.5	0	4	2.5	4	2.5	2.5	2.5	120	D	22	13	F	SLE1DF02V8B05
	6.0	0.8	0	3	3	3	1.5	2	1	120	D	22	13	F	SLE1DF02V8B06
3/8"	5.0	0.5	0	4	2.5	4	2.5	2.5	2.5	120	D	22	13	F	SLE1DF02V8C05
	6.0	0.8	0	3	3	3	1.5	2	1	120	D	22	13	F	SLE1DF02V8C06
	9.0	1.65	0	1	1	0.8	0.4	0.5	0.3	120	D	22	13	F	SLE1DF02V8C09
1/2"	5.0	0.5	0	4	2.5	4	2.5	2.5	2.5	120	D	22	13	F	SLE1DF02V8D05
	6.0	0.8	0	3	3	3	1.5	2	1	120	D	22	13	F	SLE1DF02V8D06
	9.0	1.65	0	1	1	0.8	0.4	0.5	0.3	120	D	22	13	F	SLE1DF02V8D09

SLE Series Coils Characteristics List

Coils Model Code	Voltage	Power consumption					Suitable Valve Model
		50HZ VA		60HZ VA		DC W	
		Inrush	Holding	Inrush	Holding		
D04-3101	AC220V	55	22	55	22	SLE Normally Closed Series	
D04-3102	AC110V	55	22	55	22		
D04-3104	AC24V	45	18	45	18		
D04-3106	DC24V	—————					13
D04-3107	DC12V	—————					13

Sanlixin Solenoid Valve

SLE manifold type series solenoid valve

Main Technical Parameters

2-way solenoid valve normally closed, closed when de-energized, open when energized.

One inlet many outlets(n); two inlets many outlets(n)

- Body material: brass
- Internal component: stainless steel
- Seal: NBR(media temp.: < = 80°C)
- EPDM(media temp.: < = 120°C)
- VITON(media temp.: < = 120°C)
- Operating media: water, hot water, gas, oil (<=20cst)
- Orifice: Φ 10.0mm
- Connection: outlet connection: 1/4" 3/8" 1/2"
inlet connection: 1/2"
- Operating pressure: 0~13kgf/cm²
- Voltage: AC220v 110v 24v 50/60hz DC24v 12v
- Power consumption: AC22va (13w) DC13w
- Voltage tolerance: -10%~+10%
- Coil type: D=DIN Standard Connections Fully Encapsulated.
N=lead wires
- Coils can be use Nass Coil
- Heat resistant class: class F 155°C Ed100%
- Ambient temp: 0~65°C



Solenoid Valve Numbering System for Order

	1	2	3		4	5	6	7	8	9	10
	Valve Series	Mode of Operation	Coil Type	Coils Class	Voltage	Seal Material	Body Material	Pipe Size	Orifice	Composition	Options
E.G.	SLE	1	D	F	02	V	1	D	10	N3	K
		I= Normally Closed	D=DIN standard connections, fully encapsulated N=lead wires water-tight fully encapsulated S= NASS coil	F Class	02= AC220V 01= AC110V 12= DC12V 13= DC24V	N= NBR E= EPDM V= VITON	1= Forged Brass	B= 1/2"×1/4" C= 1/2"×3/8" D= 1/2"×1/2"	10.0 mm	N2= 2Pcs N3= 3Pcs N8= 8Pcs	N=NPT L=Neon Lamp

SLE manifold type series solenoid valve

External Dimensions Chart

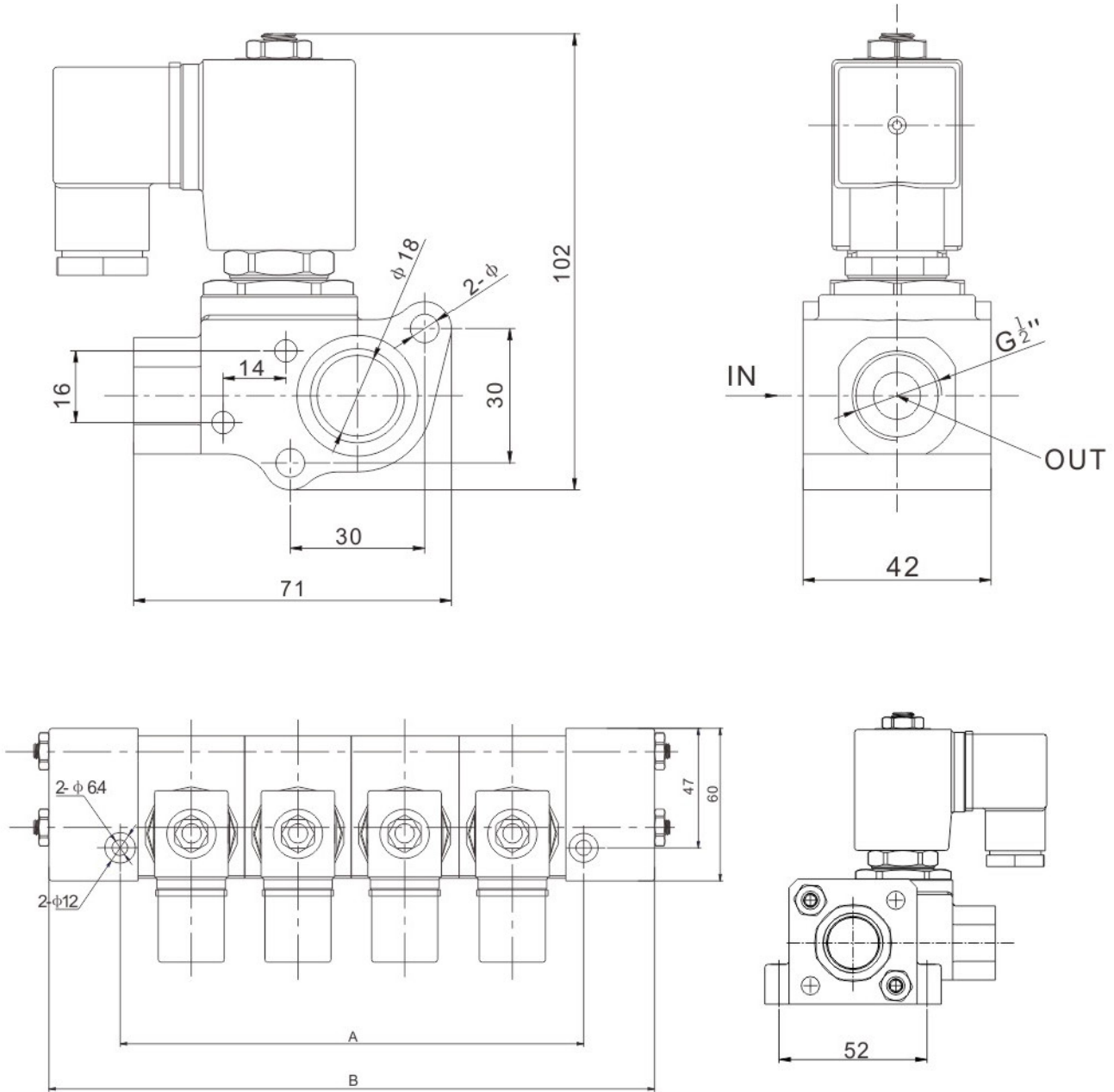

composition No	2	3	4	5	6	7	8
A: Mounting distance	94	136	178	220	262	304	346
B: total length	120	162	204	246	288	330	372
Weight (KG)	1.9	2.7	3.5	4.4	5.2	5.9	6.8

Sanlixin Solenoid Valve

SLE manifold type series solenoid valve

N PCS solenoid valves mounting connection diagram

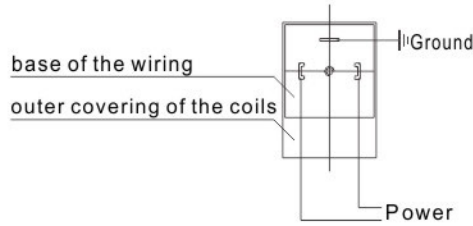
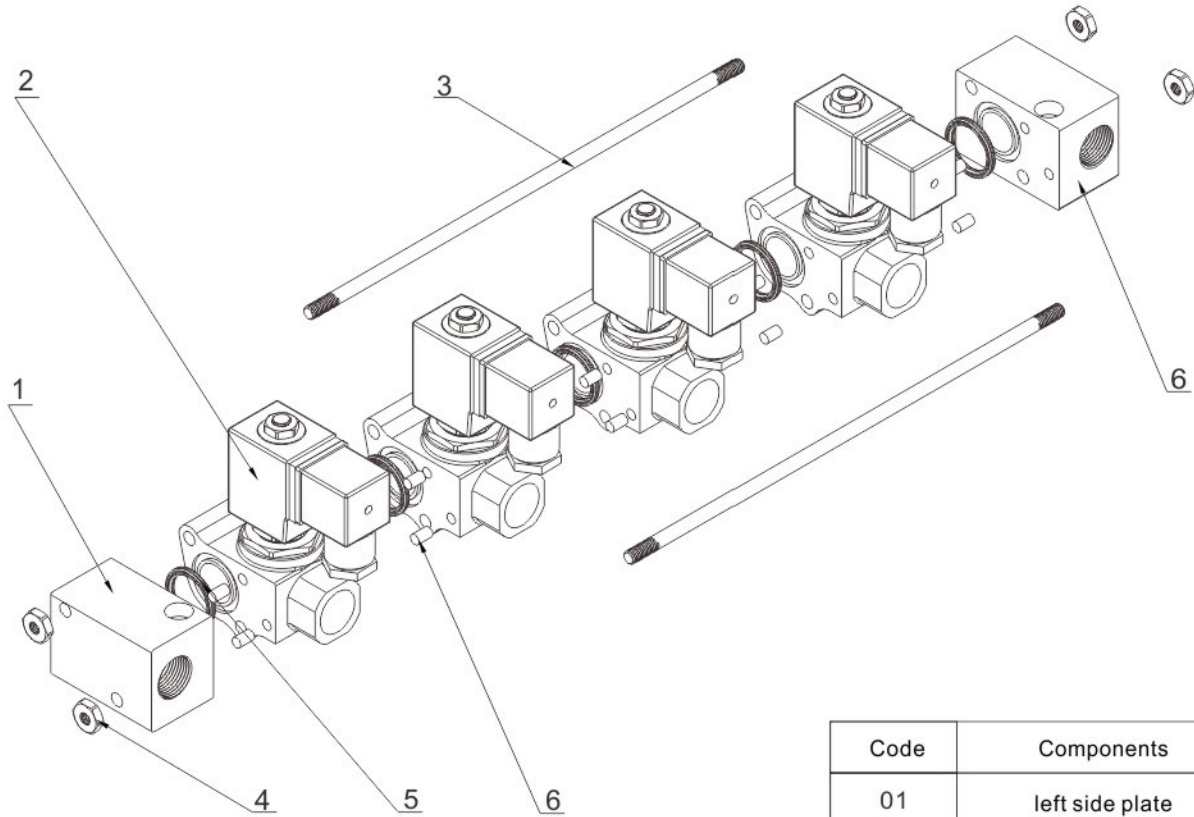

Code	Components
01	left side plate
02	single solenoid valve
03	connecting screw
04	joint nut
05	star type O ring
06	Dowel
07	right side plate

Coil dimensioned chart

N=Lead wires, water-tight Fully Encapsulated

DIN Standard Connections

