



Features

Double rod with double force for higher anti-bending and anti-twisted strength ensured durable life and perfect directional characteristic.

Ordering Code

TN	20	50	MT
Type	Bore	Stroke	Sensor
TN: Double-shaft double acting	10 16 20 25 32		CSI-J

* TN Series attached magnetic ring

Symbol

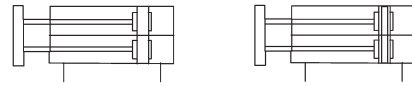

Specification

Bore (mm)	10	16	20	25	32
Working Medium	Air				
Operation	Double Acting				
Operation Pressure Range	0.1~0.9 MPa				
Ensure Pressure Resistance	1.35 MPa				
Operation Temperature Range	0~70 °C				
Operation Speed Range	100~500 mm/s				
Adjustable Stroke	-10~0 mm				
Cushion	Not Available	Cushioning Gasket			
Presion Of Non-rotating	0.4°	0.3°			
Port Size	M5 x 0.8				PT 1/8"

The Max. operating pressure is subject to the Max. load of hydraulic buffer.

Stroke

Bore (mm)	Standard Stroke													Max. Stroke	Allowable Stroke
10	10	20	30	40	50	60	70							70	100
16	10	20	30	40	50	60	70	80	90	100	125	150	150	200	
20	10	20	30	40	50	60	70	80	90	100	125	150	150	200	
25	10	20	30	40	50	60	70	80	90	100	125	150	150	200	
32	10	20	30	40	50	60	70	80	90	100	125	150	150	200	

TN Series

Double Rod Cylinder



The way to automation

- Cylinder
- Sizing
- SI
- SI A.
- SC / SU
- SCT
- SC A.
- DSN
- DSN A.
- MA
- MAL
- MA/MAL A.
- SDA
- CQ2
- CJ2
- CDU
- TN**
- CXS
- MGP
- MSQ

Overall Dimension

TN

Ø16~Ø25

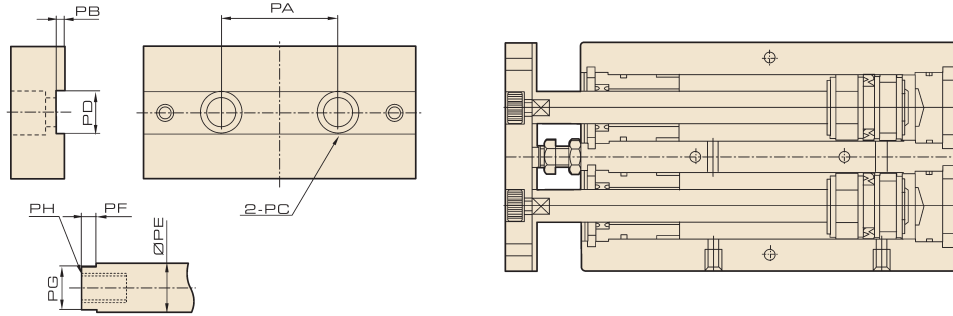

Dimension

Bore / Symbol	PA	PB	P1	PD	PE	PF	PG	P2
10	18	0.5	Φ6.2 deep 3.5 mm, Through Hole: Φ4.5	5.2	6	3	5.2	M3 × 0.5 deep 5 mm
16	24	1	Φ7.8 deep 4.6 mm, Through Hole: Φ4.5	6.2	8	3	6.2	M4 × 0.7 deep 46 mm
20	28	1	Φ11 deep 6.8 mm, Through Hole: Φ4.5	8.2	10	3	8.2	M6 × 1 deep 48 mm
25	34	1	Φ11 deep 6.8 mm, Through Hole: Φ4.5	10.2	12	3	10.2	M6 × 1 deep 48 mm
32	42	2	Φ17 deep 12 mm, Through Hole: Φ4.5	14	16	3	14	M10 × 1.5 deep 14 mm

Overall Dimension

Allowable size load

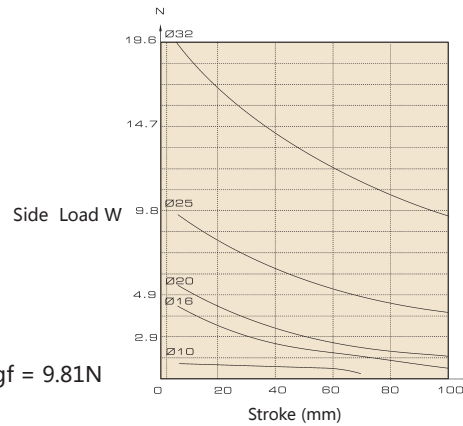
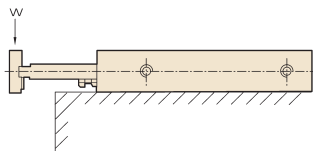

Dimension

O-ring List

Inner Diameter Quantity	Front cover seal	Piston O-ring	Rear cover O-ring	Piston rod O-ring
	1	2	2	1
10	PDU-6	APA-10	10×1.5	P12
16	PDU-8	APA-16	16×1.5	P16
20	PDU-10	APA-20	20×1.5	P20
25	PDU-12	APA-25	25×1.5	P20
32	PDU-16	APA-32	32×1.5	P25

Overall Dimension

TN

Ø10

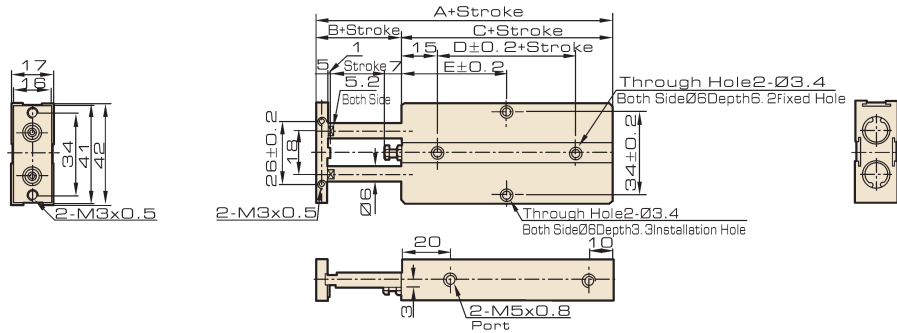

Ø16~Ø25

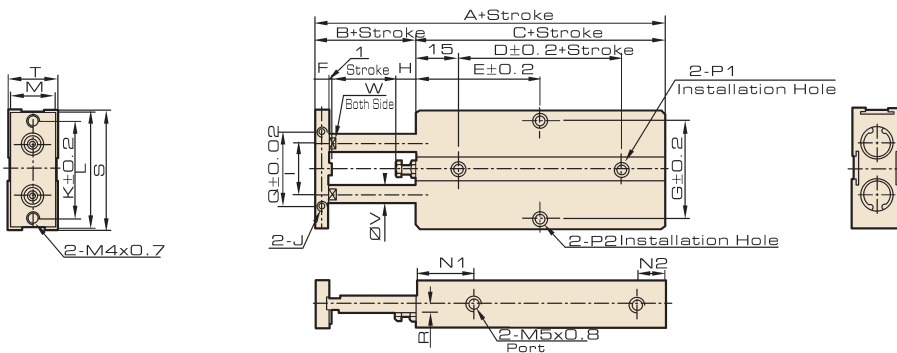

Ø32

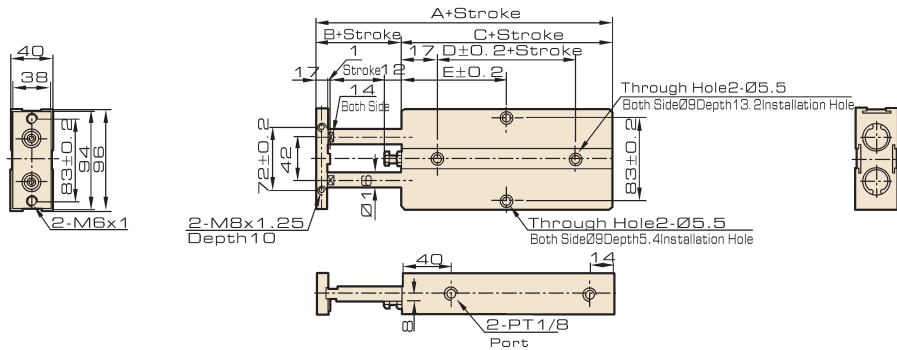

Dimension

Bore Symbol	A	B	C	D	E											F	G	H	I	
					10	20	30	40	50	60	70	80	90	100	125					150
16	68	15	53	20	30	35	40	45	50	55	60	65	70	75	87.5	100	8	47	6	24
20	78	20	58	20	35	35	40	45	50	55	60	65	70	75	87.5	100	10	55	9	28
25	81	19	62	30	40	40	45	50	55	60	65	70	75	80	92.5	105	10	66	8	34

Bore Symbol	J	K	L	M	N1	N2	P1		P2		Q	R	S	T	V	W
							Double side: Ø7.5 Deep: 7.2 mm, Through Hole: Ø4.5	Through Hole: Ø4.5	Double side: Ø8 Deep: 4.4 mm, Through Hole: Ø4.5	Through Hole: Ø4.5						
16	M4x0.7 deep 5	47	53	20	22	10	Double side: Ø7.5 Deep: 7.2 mm, Through Hole: Ø4.5	Through Hole: Ø4.5	Double side: Ø8 Deep: 4.4 mm, Through Hole: Ø4.5	Through Hole: Ø4.5	34	3	54	21	8	6.2
20	M4x0.7 deep 5	55	61	24	25	12	Double side: Ø7.5 Deep: 7.2 mm, Through Hole: Ø4.5	Through Hole: Ø4.5	Double side: Ø8 Deep: 4.4 mm, Through Hole: Ø4.5	Through Hole: Ø4.5	44	3.5	62	25	10	8.1
25	M4x0.8 deep 6	66	72	27	30	12	Double side: Ø7.5 Deep: 7.2 mm, Through Hole: Ø4.5	Through Hole: Ø4.5	Double side: Ø8 Deep: 4.4 mm, Through Hole: Ø4.5	Through Hole: Ø4.5	56	7	73	30	12	10.2

Bore Symbol	A	B	C	D	E											
					10	20	30	40	50	60	70					
10	63	12	51	10	30	30	35	40	45	50	55					
32	108	30	78	35	10	20	30	40	50	60	70	80	90	100	125	150
					45	50	55	60	65	70	75	80	85	90	102.5	115

- Cylinder
- SI
- SI A.
- SC / SU
- SCT
- SC A.
- DSN
- DSN A.
- MA
- MAL
- MA/MAL A.
- SDA
- CQ2
- CJ2
- CDU
- TN**
- CXS
- MGP
- MSQ